

Alto.

Specifications

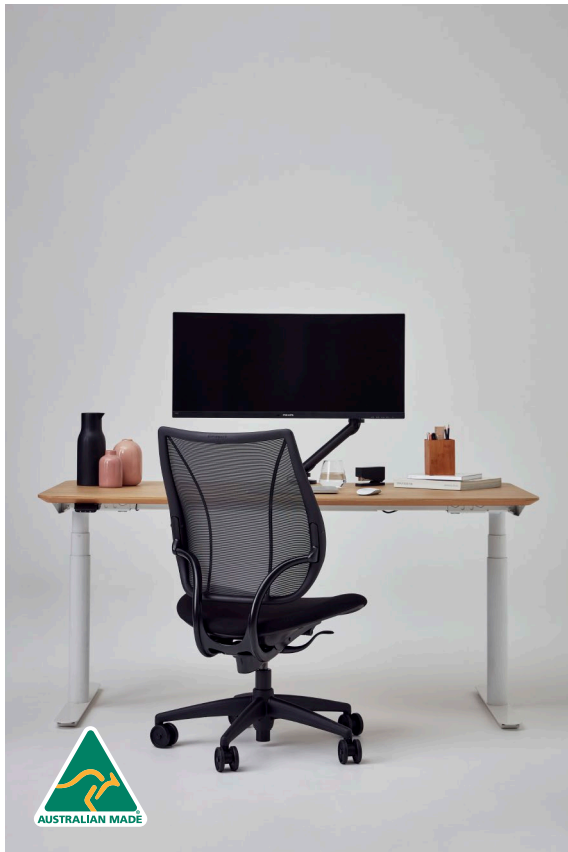

Alto is a proven workstation system combining the highest quality components to deliver a complete sit-to-stand workstation offering.

Equipped with standard features such as anti-collision sensors, low noise levels, Alto works seamlessly with our developed range of workstation screen, cable management and power and data systems - and all available in a range of clusters, sizes and finishes.

AWM's fixed height and sit-to-stand Alto workstations are manufactured and assembled in our Sydney factory, guaranteeing the highest standards of quality, functionality and sustainability.

Lead Time: 3 - 4 Weeks

10 Year Warranty

GECA Level A Certified

AFRDI Blue Tick Certified



Alto.

Typical Configurations

Warranty	10 Years
Lead Time	3 - 4 Weeks
Manufacture	Leg Mechanism - Denmark All Other Components - Australia
Leg Profiles	Round - Ø70mm outer profile Rectangle - 60 x 100mm outer profile
Height Range	620 - 1285mm (including 25mm desktop)
Speed	38mm/s
Anti-Collision	Integrated PEIZO sensor
Finishes	Black (RAL 9005) or White (RAL 9016)
Accreditations	GECA Certified Level A AFRDI Blue Tick Certified

L-Shaped

3 x Motors per Workpoint

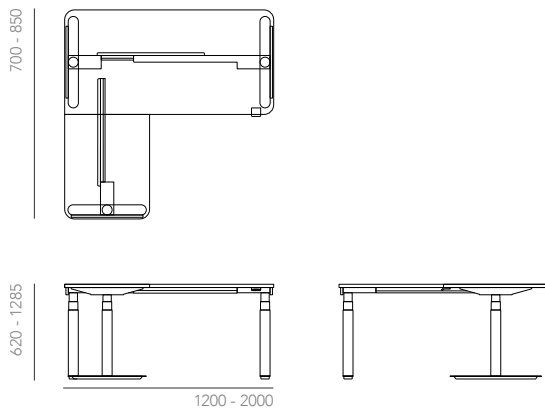

120°

3 x Motors per Workpoint

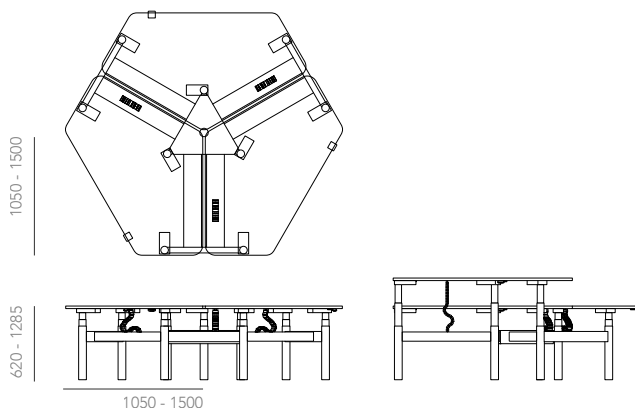

Single Sided

2 x Motors per Workpoint

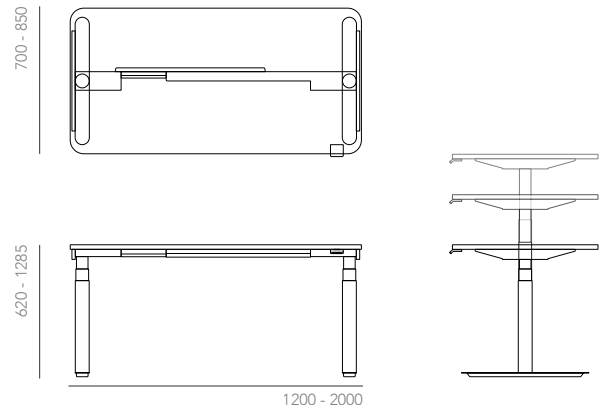

Back-to-Back

2 x Motors per Workpoint

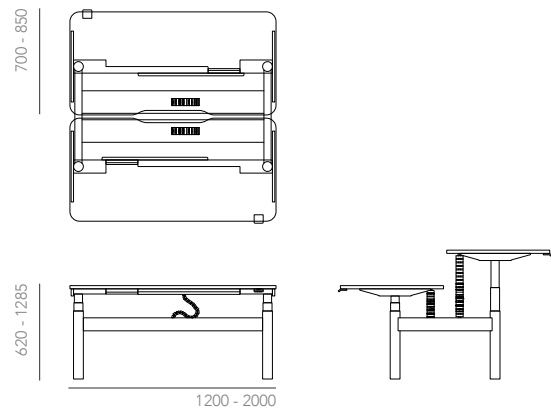

Quad

3 x Motors per Workpoint

